

ODI LOCK-ON WATERCRAFT GRIPS INSTALLATION

PLEASE READ ALL INSTRUCTIONS/PRECAUTIONS BEFORE INSTALLING GRIPS!

⚠ WARNING: ODI LOCK-ON GRIPS ARE NOT DESIGNED FOR USE WITH NOTCHED HANDLEBARS OR ANY HANDLEBAR THAT IS CUT SO THAT THE BAR IS NOT COMPLETELY ROUND. PROPER ADAPTERS MUST BE USED ON THESE BARS IN ORDER TO MAKE COMPATIBLE WITH ODI LOCK-ON GRIPS. NOTE THAT BOTH LOCK JAW CLAMPS MUST BE INSTALLED COMPLETELY ONTO THE HANDLEBAR IN ORDER FOR THE GRIPS TO FUNCTION PROPERLY. FAILURE TO FOLLOW THESE GUIDELINES WILL VOID ANY WARRANTY AND COULD CAUSE INJURY IN THE EVENT OF A FAILURE. IT IS RECOMMENDED THAT THE GRIPS BE INSTALLED BY A QUALIFIED WATERCRAFT SERVICE CENTER.

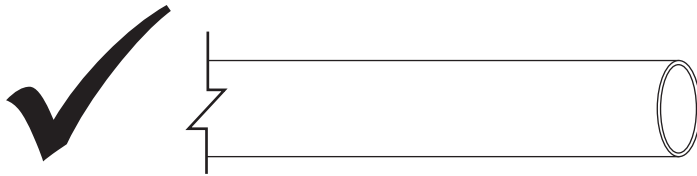

GRIP AREA OF HANDLEBAR MUST BE COMPLETELY ROUND.

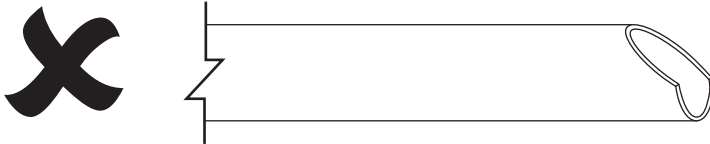

DO NOT USE ON CUT HANDLEBARS!!

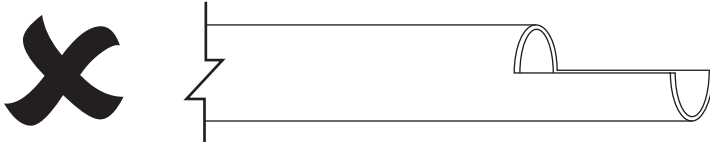

DO NOT USE ON NOTCHED HANDLEBARS WITHOUT PROPER ADAPTERS!!

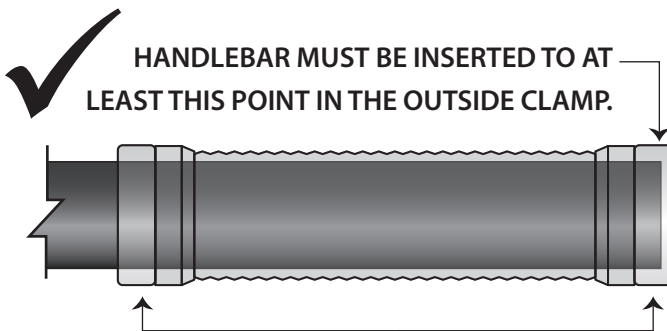

HANDLEBAR MUST BE INSERTED TO AT LEAST THIS POINT IN THE OUTSIDE CLAMP.

BEFORE INSTALLATION- CONFIRM THAT THERE IS SUFFICIENT SPACE AVAILABLE ON THE HANDLEBARS SO THAT BOTH LOCK JAW CLAMPS CAN BE CLAMPED ONTO THE HANDLEBAR.

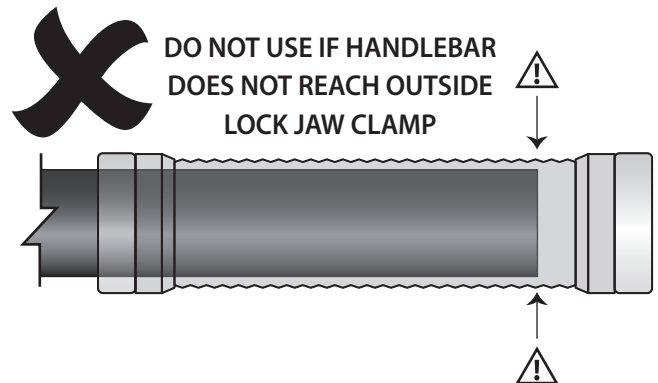

DO NOT USE IF HANDLEBAR DOES NOT REACH OUTSIDE LOCK JAW CLAMP

DO NOT USE GRIPS IF BOTH CLAMPS ARE NOT ABLE TO BE CLAMPED ONTO THE HANDLEBAR! THIS CAN CAUSE GRIPS TO BREAK AND/OR FAIL AND MAY RESULT IN SERIOUS INJURY!

ODI LOCK-ON WATERCRAFT GRIP INSTALLATION INSTRUCTIONS

- ① Install Lock Jaw Clamps on both sides of the grip by first inserting one of the ears on the grip into the recess on one side of the clamp and while holding the clamp in this position, pull down on the opposite side to snap clamp into place on both ears. You should hear an audible “snap” when they are fully inserted. Follow the same procedure for the remaining Clamps.
- ② (Optional) install Snap caps into outside Clamp on both grips by placing the grip on a flat surface and pushing the lip on the inside of the Snap Cap into the groove on the inside diameter of the clamp. Again you should hear an audible “snap” when they are fully inserted. Snap Caps are optional and are included to close off the end of the grip if desired.
- ③ Install M3.5 Stainless Steel Bolts into each of the 4 Lock Jaw Clamps.
- ④ Slide grip into desired position on handlebar. NOTE: Both clamps must be clamped onto the handlebar for grips to function correctly. (See opposite side for warnings and precautions!)
- ⑤ Tighten the Bolts in each of the Lock Jaw Clamps using a 2.5mm Allen Key. The recommended amount of torque for the 2.5mm screw into the Lock Jaw Clamp is 26 - 30 inch pounds or 4NM . (NOTE: DO NOT Exceed 40 inch poundsto avoid stripping the head of the allen bolt.)
- ⑥ If a small amount of play develops in the grips, you can correct this by loosening one clamp on the grip and twisting it in either direction and re-tightening the bolt while maintaining torsional pressure. If this method does not reduce play in the grips, discontinue use and replace grips.

**FOR MORE INFORMATION, PLEASE VISIT ODIGRIPS.COM/INSTALL
QUESTIONS? CONTACT US AT INFO@ODIGRIPS.COM**